

1. Concrete strength to be 5,000 psi after 28 days
2. Manhole wall, transitions, conical sections, and bases shall conform to ASTM C478. Conical sections shall be designed to meet or exceed all requirements of the latest MASHHD HS-20 Loading.
3. Joints between the precast units shall be sealed with flexible watertight rubber gaskets conforming to ASTM C 990 or C445 and wrapped externally, ASTM C 877 (tube III - Chemically Bonded Adhesive Butyl Bands) - Applied by installation contractor.
4. Sewer pipe to manhole connections shall be sealed with integrally Cast Flexible connectors according to section C925
5. All manholes shall be precast with Xypex and GorShield per Section 803. All interior surfaces (including benches) of new sanitary sewer manholes at force main entry locations and one manhole down stream of the force main entry shall be given and interior coating of Pilgrim Liner Guard 100C Per System 108.
6. Manholes of 60" Dia. shall be used for 16" up to 24" pipe.
7. External Wrap Per Section 803
8. Manholes shall not include steps.

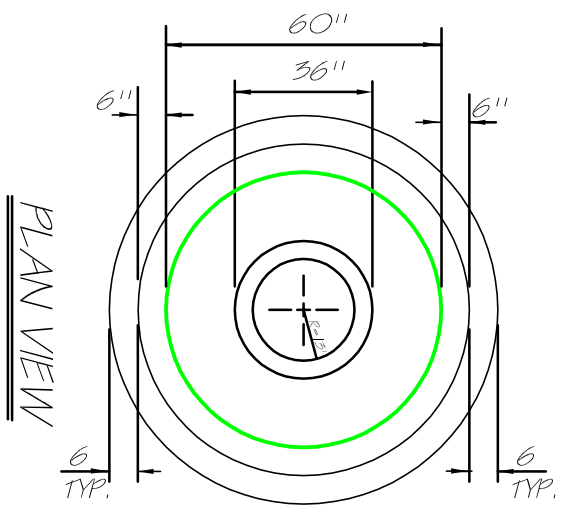

MANHOLE
5' Dia.
by: THOMAS F. PERTUIT, P.E.

WASTEWATER TREATMENT OF LOUISIANA, INC.

17188 Airline Hwy, Ste M-157 Prairieville, LA 70769  
 PH 225-673-3156